

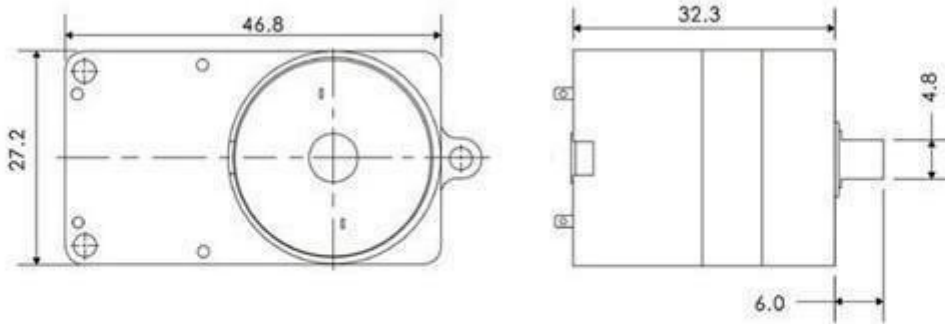

**GP08-300CA**

**DIBUJO**



UNIT : Millimeters WEIGHT : 36 g (APPROX)

**CARACTERISTICAS**

MODEL	REDUCTION RATIO	VOLTAGE		NO LOAD		AT MAXIMUM EFFICIENCY				STALL				
		OPERATING RANGE	NOMINAL	SPEED	CURRENT	SPEED	CURRENT	TORQUE	OUTPUT	TORQUE	CURRENT			
		VDC	VDC	RPM	A	RPM	A	mN.m	g.cm	W	mN.m	g.cm	A	
GP08-300CA	11440	220	3.0~6.0	4.0	18	0.04	15	0.17	110.0	907.5		294.0	3000	0.35