

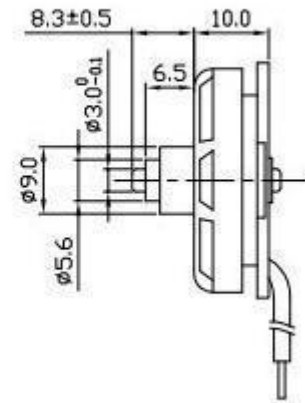

ABL-RC3010

DIBUJO

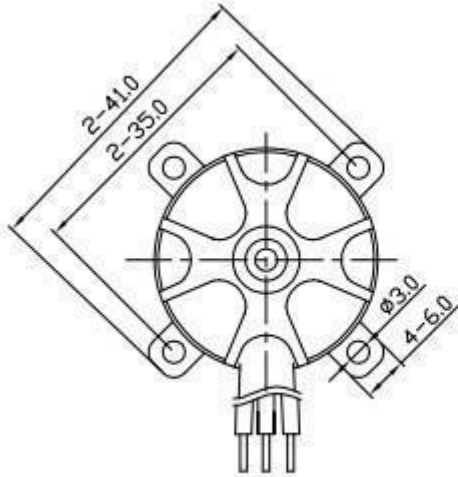

UNIT : Millimeters WEIGHT : 21 g (APPROX)

CARACTERISTICAS

MODEL	VOLTAGE		NO LOAD			AT LOAD				STALL			
	OPERATING RANGE	NOMINAL	SPEED	CURRENT	SPEED	CURRENT	TORQUE	OUTPUT	TORQUE	CURRENT			
	VDC	VDC	KV	RPM	A	RPM	A	mN.m g.cm	W	mN.m g.cm	A		
ABL-RC3010	01	5~10	7.0	1600	11200	0.5		4.0			30		
	02	5~10	7.0	1550	10850	0.5		3.5			24		